

PRIMARY COLLECTION VEHICLE 4.5cum CAPACITY WITH HYDRAULIC ARRANGEMENT

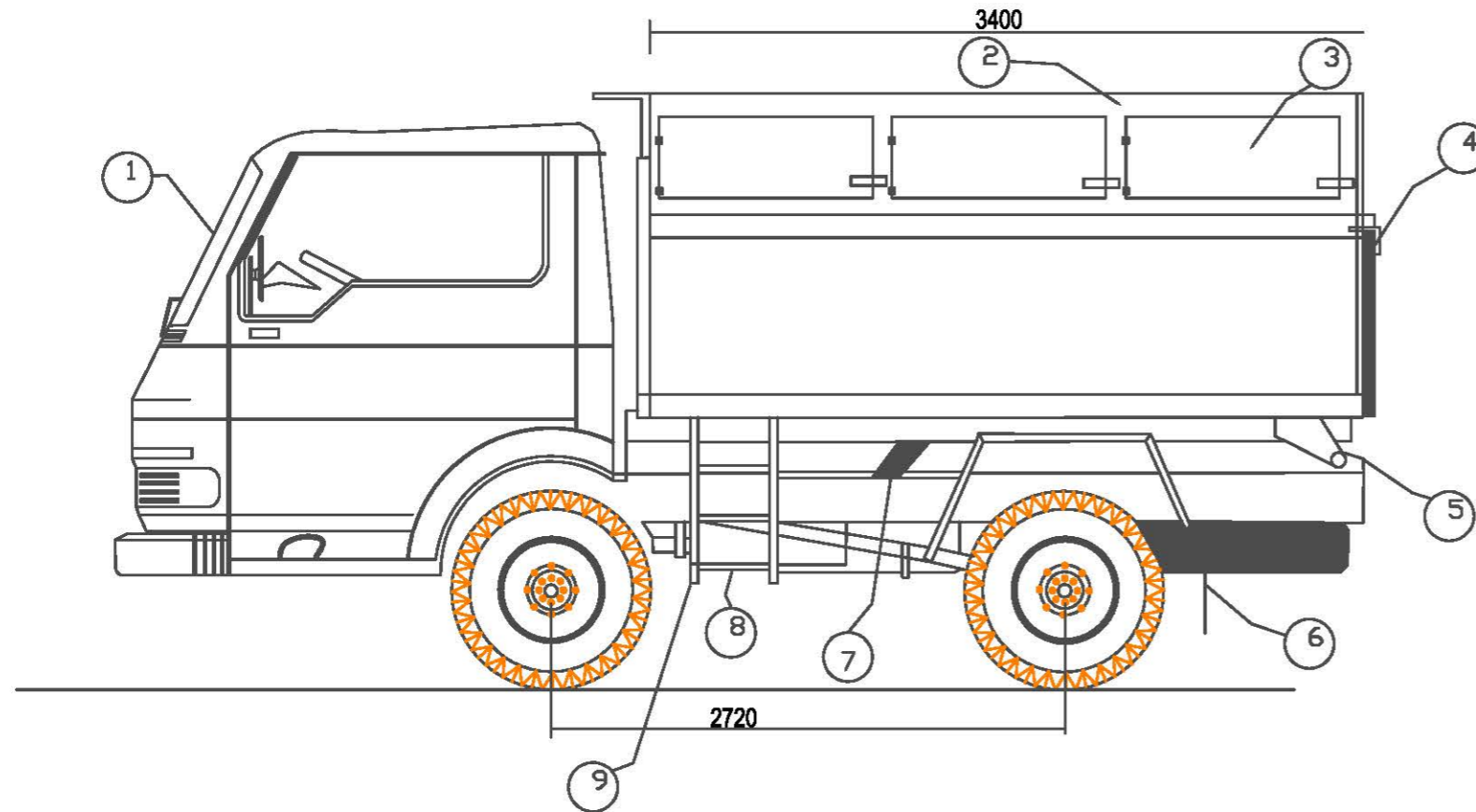

DIMENSIONS OF 4.5 cum VEHICLE WITH HYDRAULIC ARRANGEMENT FROM SIDE VIEW

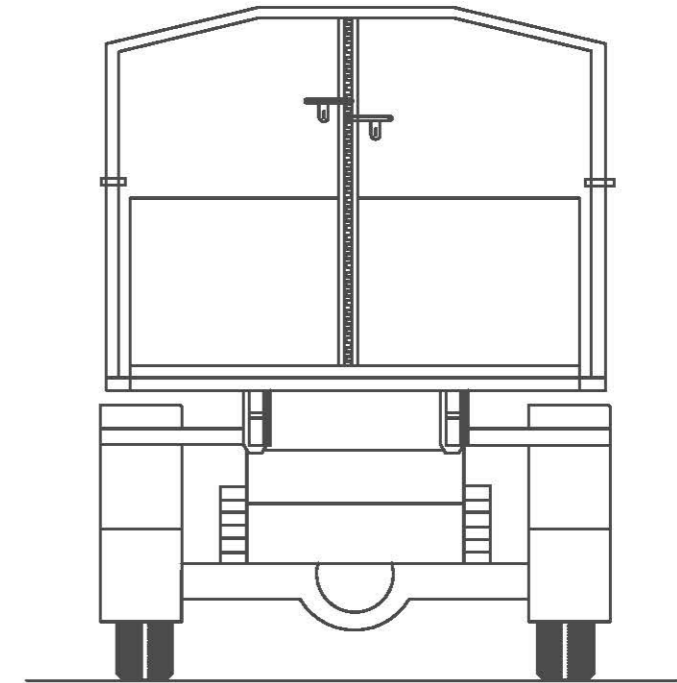

DIMENSIONS OF THE VEHICLE FROM BACK VIEW

ALL DIMENSIONS ARE IN MM

S.NO	DRW/PART/NO	DESCRIPTION	MTRL	QTY	WT.IN Kgs
1	--	VEHICLE CABIN	STD	01	--
2	--	TIPPER BODY	M.S	01	--
3	--	SIDE DOOR	M.S	04	--
4	--	REAR DOOR WITH LOCK	M.S	01	--
5	--	SKID	M.S	01	--
6	--	MUD GUARD	M.S	02	--
7	--	HYDRAULLIC CYLINDER	STD	01	--
8	--	WORKING PLATFORM	M.S	02	--
9	--	LADDER	M.S	02	--



Mott MacDonald
2nd Floor, Bellevue Mansion
Opposite Clinical Research Unit
(Tribal) for Homoeopathy.
Malki - Dhankheti
Shillong - 793001,
Meghalaya, India

T +91 (0) 364 2505 446
F
W www.mottmac.com

Client
State Investment Program Management
and Implementation Unit (SIPMIU)
Government of Meghalaya

Rev	Date	Drawn	Description	Ch'k'd	App'd
R0	01.02.2014	L.L	Detail Project Report	T.S	B.K.H

Title
North Eastern Region Capital Cities
Development Investment Programme
For Shillong, Solid Waste Management
Garbage Tipper Vehicles 4.5 cum
(Sheet no 2 of 2)

Drawing Number
MMD-260652-C-DR-00-SWM-0006

Drawn	L.Lyngdoh
Checked	S.M
Approved	S.K.S
Scale at A3 NTS	
Status	Rev
DPR	R0